

auto electrical parts

Technical Information Sheet

Part No. 0-071-50

Commercial 6 in 1 LED rear lamp 12/24V, right hand. Stop / tail / direction indicator / fog / reflex reflector / reverse.

ECE approved. IP67.

Dimensions

l 385 x w 33.5 x h 150mm.



Technical Drawing (not to scale)

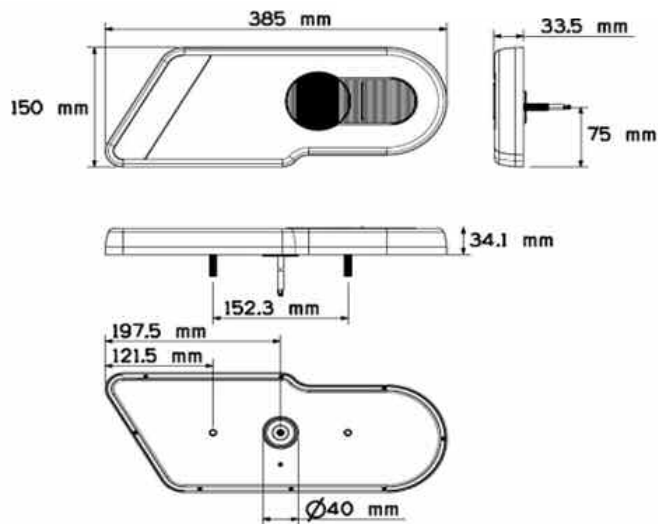

Specification

Type	Commercial LED rear lamp
Voltage	12/24v
Function	Stop/tail/direction indicator/fog/reflex reflector/reverse
Lens	Polycarbonate
IP Rating	IP67
Dimensions	l 385 x w 33.5 x h 150mm.
Compliance	ECE

The information contained in this document is correct to the best of our knowledge at the time of printing. However, specifications may change at any time without notice.